

SB5560S 55A SCRs

FEATURES

- High thermal cycling performance
- High voltage capacity
- Very high current surge capability

APPLICATIONS

- Line rectifying 50/60 Hz
- Softstart AC motor control
- DC Motor control
- Power converter
- AC power coil control
- Lighting and temperature control

Parameters Summary

VD/VR:1200/1600V IT(RMS):55A IGT :60mA

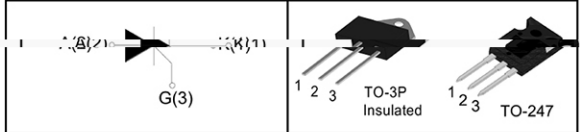

ABSOLUTE MAXIMUM RATINGS				
Parameter	Symbol	value	Unit	
Storage junction temperature range	Tstg	-40 ~ 150	°C	
Operating junction temperature range	Tj	-40 ~ 125	°C	
Repetitive peak off-state voltage (T=25°C)	V _{DRM}	1200/1600	V	
Repetitive peak reverse voltage (T=25°C)	V _{RRM}	1200/1600	V	
Non repetitive surge peak Off-state voltage	V _{DSM}	V _{DRM} +100	V	
Non repetitive peak reverse voltage	V _{RRSM}	V _{RRM} +100	V	
RMS on-state current	TO-3PIns.(TC=80°C)	I _{TSM}	55	A
	TO-247(TC=85°C)			
Non repetitive surge peak on-state current	I _{TSM}	550	A	
Average on-state current (180° conduction angle)	I _{T(AV)}	35	A	
I ² t value for fusing (tp=10ms)	I ² t	1500	A ² S	
Critical rate of rise of on-state current (I=2×IGT, tr ≤ 100 ns)	di/dt	150	A/μS	
Peak gate current	I _{GM}	5	A	
Average gate power dissipation	P _{G(AV)}	2	W	

Thermal Resistances				
Symbol	Parameter	Value	Unit	
Rth(j-c)	Junction to case (DC)	TO-3P	0.65	°C/W
		TO-247	0.60	

Symbol	Test Condition	Value
V_{DRM}	$V_D = V_{DRM}$ $T_j = 125^\circ\text{C}$	MIN. 60 MAX. 100
V_{GD}	$V_D = V_{DRM}$ $T_j = 125^\circ\text{C}$	MIN. 0.2 MAX. 0.5
$I_{T(RMS)}$	$I_a = 1.2 I_{T(RMS)}$	MAX. 250
I_H	$I_H = 50\text{mA}$	MAX. 200
dV/dt	$V_a = 0.2V$ $f_{DRM} = 100\text{Hz}$ $T_j = 125^\circ\text{C}$	MIN. 1000

Symbol	Value
V_{DRM}	60-100
V_{GD}	0.2-0.5
$I_{T(RMS)}$	250
I_H	200
dV/dt	1000

Ordering information Scheme

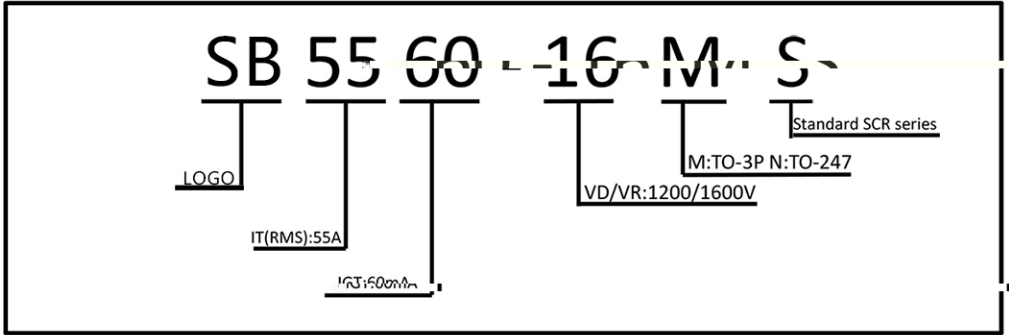

TO-3P Package Mechanical Data

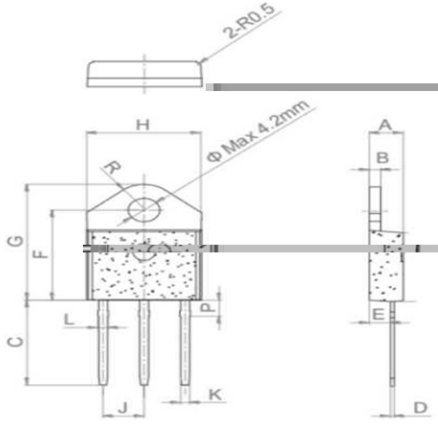

Ref.	Millimeters	Inches
A	1.60	0.063
B	1.60	0.063
C	1.48	0.058
D	0.70	0.027
E	0.70	0.027
F	0.60	0.024
G	2.02	0.079
H	1.15	0.045
J	0.14	0.005
K	1.30	0.051
L	1.28	0.050
P	0.40	0.016
R	0.40	0.016

TO-247 Package Mechanical Data

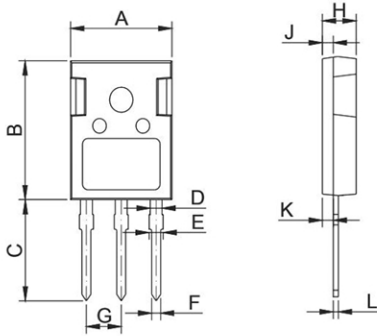

Ref.	Dimensions					
	Millimeters			Inches		
	Min.	Typ.	Max.	Min.	Typ.	Max.
A	15.50	15.80	16.10	0.610	0.622	0.634
B	20.80	21.00	22.20	0.819	0.828	0.874
C	19.70	20.00	20.30	0.776	0.787	0.799
D	1.80	2.00	2.00	0.071	0.079	0.079
E	1.90	2.10	2.30	0.075	0.083	0.091
F	1.00	1.20	1.40	0.039	0.047	0.055
G		5.44			0.214	
H	4.80	5.00	5.20	0.189	0.197	0.205
J	1.90	2.00	2.10	0.075	0.079	0.083
K	2.20	2.35	2.50	0.087	0.093	0.098
L	0.41	0.60	0.79	0.016	0.024	0.031

FIG.1 Maximum power dissipation versus on-state current

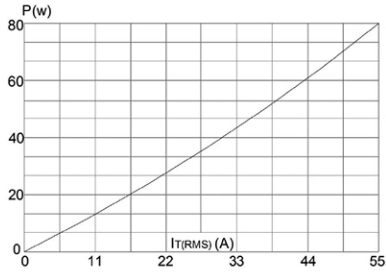

FIG.2: on-state current versus case temperature

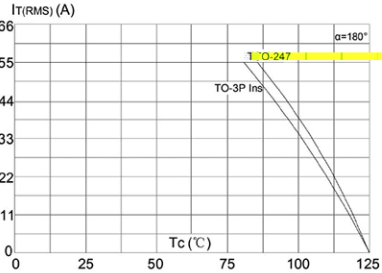

FIG.3: Surge peak on-state current versus number of cycles

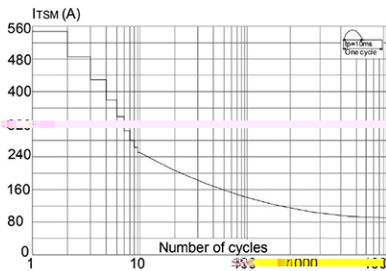

FIG.4: On-state characteristics (maximum values)

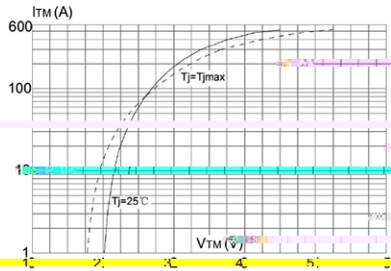

FIG.5: Non-repetitive surge peak on-state current for a sinusoidal pulse with width $t_p < 10\text{ms}$, and corresponding value of $1/2 t$

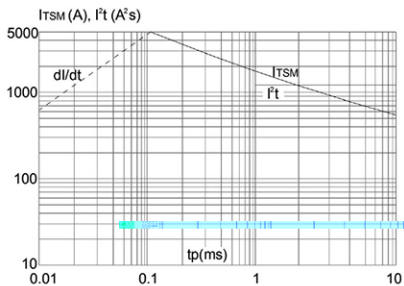

FIG.6: Relative variation of I_{GT} and $I_{H\&L}$ versus junction temperature

